

SRC550H

SRC550H ROUGH-TERRAIN CRANE
55 TONS LIFTING CAPACITY

Quality Changes the World

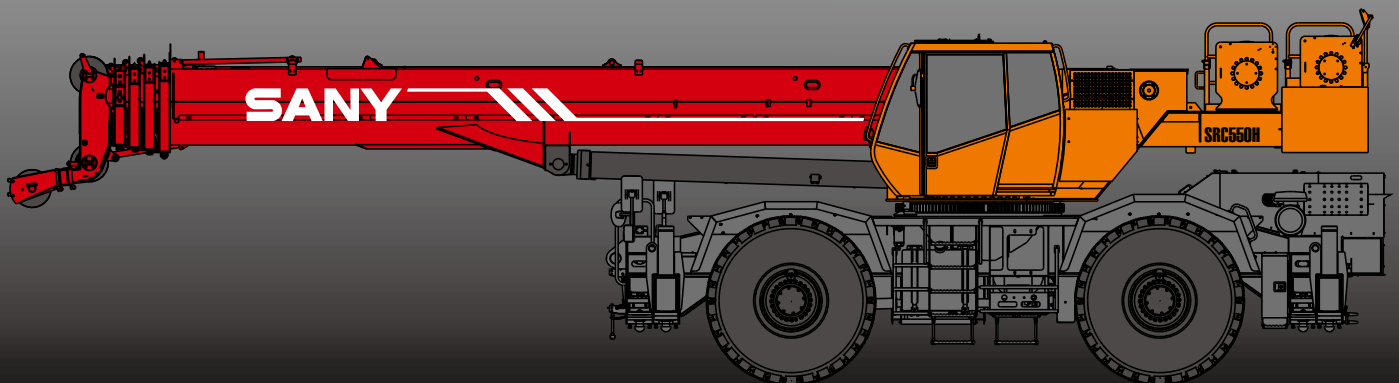

SANY

Courtesy of Crane.Market

■ SANY Automobile Hoisting Machinery is one of the core business unit of Sany Heavy Industry, mainly engaged in the research and development of high end, mid to large tonnage crane series, including mobile crane, crawler crane, tower crane and loader crane. It has two industrial parks in Ningxiang and Huzhou, since entering the market, the products of Sany Automobile Hoisting Machinery have received worldwide recognition with advanced technology, lean manufacturing, high reliability and excellent service.



SANY ROUGH-TERRAIN CRANE

CONTENT

- 04 Icon
- 05 Selling points
- 06 Introduction
- 09 Dimension
- 11 Technical Parameter
- 12 Operation Condition
- 13 Load Chart
- 18 Wheel Crane Family Map

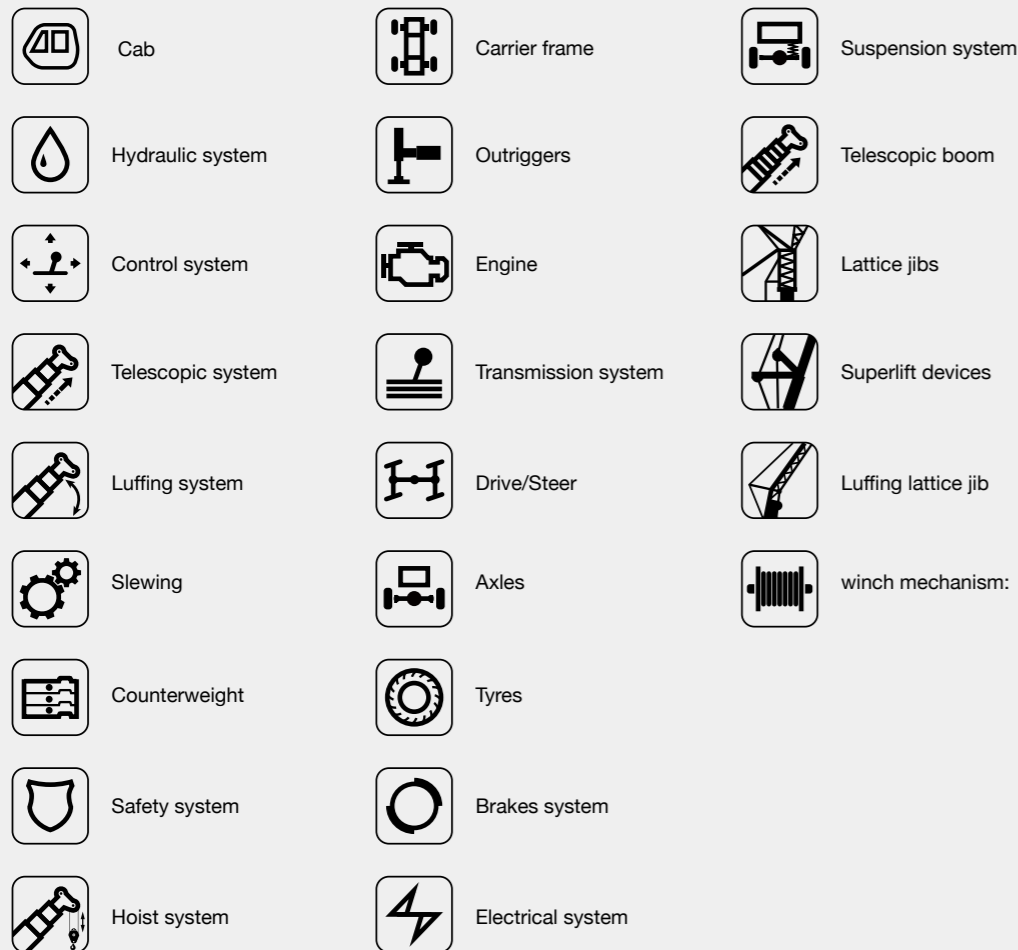

Excellent traveling capacity and high-performance chassis system

Four-wheel drive is applied with four steering modes to provide good mobility. Trafficability and comfortableness of the complex road condition is improved thanks to its Min. turning radius of no more than 6.7m with 4-wheel steering.

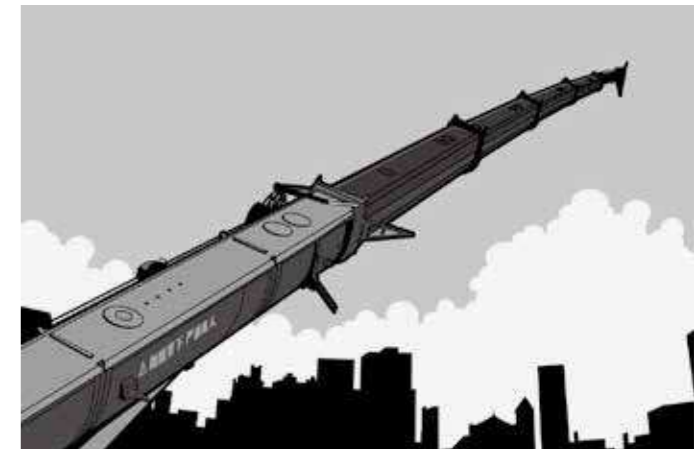

Ultra long and super strong boom system

Five-section boom of high strength steel structure and optimized U-shaped section, reducing weight and improving safety significantly. Jib mounting angles are 0°, 15° and 30°, which ensure fast and convenient change-over between different operating conditions so as to improve working efficiency of the machine.



Highly efficient and unique hydraulic system

Hydraulic system load feedback and constant power control is applied to provide strong lifting capacity and good micro-mobility. Unique steering buffer design guarantees smooth braking operation.





Safe and reliable control system

Self-developed controller SYMC specially for engineering machinery is configured. The application of CAN-bus fully digital network control technology ensures stable control signal, simple harness and high reliability. It can feedback the data information and monitor the working condition of whole crane in real-time. Load moment limiter configured with comprehensive intelligent protection system is adopted with precision within 10%. The adoption of comprehensive logic and interlock control system ensures more safe and reliable operation.

Introduction

-  **Cab**
- The self-made cab adopts ergonomic design with sliding door, safety glass, anti-corrosion steel, soft interior decoration, large interior space, panoramic sunroof and adjustable seats, air conditioner and electric window wiper etc. to provide easier and more comfortable operation. Load moment limiter display is configured to achieve the combination of main console and operating display system, making all operating condition data of lifting operation clear at a glance.

-  **Hydraulic system**
- High-quality key hydraulic components such as main oil pump, rotary pump, main valve, winch motor and balancing parts etc. are adopted to achieve stable and reliable operation of the hydraulic system. Superior operation performance is guaranteed by accurate parameter matching. Through the adoption of load sensitive variable displacement piston pump, pump displacement can be adjusted in real-time, achieving high-precision flow control with no energy loss during operation.
 - Main valve has flow compensation and load feedback control function. It significantly enhances control stability for single action and combined action under different operation conditions.
 - Winch adopts electronically controlled variable motor to ensure high operation efficiency. Max. single line speed of main and auxiliary winches is up to 150m/min.
 - Slewing system is equipped with the integrated slewing buffer valve with free slipping function to ensure more stable starting and control of the slewing operation and excellent micro-mobility.
 - Hydraulic oil tank capacity: 743L.

-  **Control system**
- CAN-bus instrument: CAN-bus instrument with a combined intelligent control electrical system is used for easy reading of the traveling parameters at any time. Engine fault warning function enables convenient and fast maintenance.
 - With full security protection system, main and auxiliary winches are equipped with over-rolling out limiter and height limiters to prevent over-rolling out and over-hoisting of steel rope, including tip-over and limit angle protection.
 - Load moment limiter: The adoption of highly intelligent load moment limiter system can comprehensively protect lifting operation, ensuring accurate, stable and comfort operation.

-  **Telescopic system**
- Five-section boom is applied with basic boom length of 11.5m, full-extended boom length of 43m, jib length of 16m and fully extended boom lifting height of 44.3m respectively. Max. lifting height is 60.6m including jib. It is made of fine grain high-strength steel, with U-shaped cross section and with telescopic operation controlled independantly by double cylinder rope.

-  **Luffing system**
- Dead-weight luffing provides more stable luffing operation at low energy loss. Dual-action single piston hydraulic pressure cylinder with safety valve is adopted. Luffing angle range is -2°—80°.

Introduction

-  **Slewing system**
- 360° rotation can be achieved with Max. slewing speed of 2.6r/min. Hydraulic controlled proportional speed adjustment is applied, providing stable and reliable operation of the system. Unique slewing buffer design ensures more stable braking operation.









-  **Counterweight**
- The total weight of fixed counterweight is 4500kg, no flexible counterweight.

-  **Safety system**
- Load moment limiter: Load moment limiter calculation system based on lifting load mechanical model is established using an analytical mechanics method with rated lifting accuracy within 10% through on-line non-load calibration, providing full protection to lifting operation. In case of overload operation, system will automatically issue an alarm, providing safety protection for manipulation.
 - Hydraulic system is configured with the balance valve, overflow valve and two-way hydraulic lock etc. components, thus achieving stable and reliable operation of the hydraulic system.
 - Main and auxiliary winches are equipped with over roll-out limiter to prevent over rolling-out of wire rope.
 - Boom and jib ends are equipped with height limiters respectively to prevent over-hoisting of wire rope.
 - Equipped with length sensor, angle sensor and press sensor to indicate the working condition of whole crane in real-time, giving an alarm and cutting off the dangerous action automatically.

-  **Hoist system**
- The adoption of pump and motor double variable speed control ensures high efficiency and excellent energy saving functionality. With perfect combination of winch balance valve and unique anti-slip technology, heavy load can be lifted and lowered smoothly. High strength, anti-swirl steel wire is equipped for high-precision hoisting positioning.
 - Equipped with one 660kg main hook and one 160kg auxiliary hook, and Main and auxiliary hook steel rope diameters are 19mm, the rope length is 235m and 165m respectively.

-  **Carrier frame**
- Carrier frame is of box-type structure that is welded with high-strength steel plate, featuring high lifting capacity.

Introduction

 Outriggers	<ul style="list-style-type: none"> H-type outrigger structure and 4-point support is adopted, with Max. span up to 7.2m×7.2m, featuring easy operation and high stability. Fine grain high strength steel material is adopted and dual-direction hydraulic lock is used for the protection of vertical cylinder of outrigger.
 Engine	<ul style="list-style-type: none"> Type: Inline six-cylinder, water cooled, supercharged and inter-cooling diesel engine Rated power: 198kw/2500r/min Environment-protection: Emission complies with State III standard Capacity of fuel tank: 300L
 Transmission system	<ul style="list-style-type: none"> Transmission case: Automatic transmission case. There are six forward gears and six backward gears in gearbox. The speed ratio range is large which meets the requirements of low gradeability speed and high traveling speed. Transmission shaft: With optimized arrangement of the transmission shaft, the transmission is stable and reliable.
 Drive/Steer	<ul style="list-style-type: none"> 4×4 drive ways and full hydraulic power steering system with front wheel steering, rear wheel steering, four-wheel steering and crab traveling modes.
 Axles	<ul style="list-style-type: none"> Axles can be flexibly controlled with two-axle designed for chassis. Front and rear axles drive are applied to ensure good power performance.
 Tyres	<ul style="list-style-type: none"> Tyres type: 4*29.5R25 ET6A
 Brakes system	<ul style="list-style-type: none"> Double-circuit braking system is adopted, if one circuit fails, the other circuit can ensure normal operation, thus improving the safety and reliability of brake system.
 Electrical system	<ul style="list-style-type: none"> With 24V free maintenance battery and mechanical power main switch, power of the whole machine can be cut off manually.

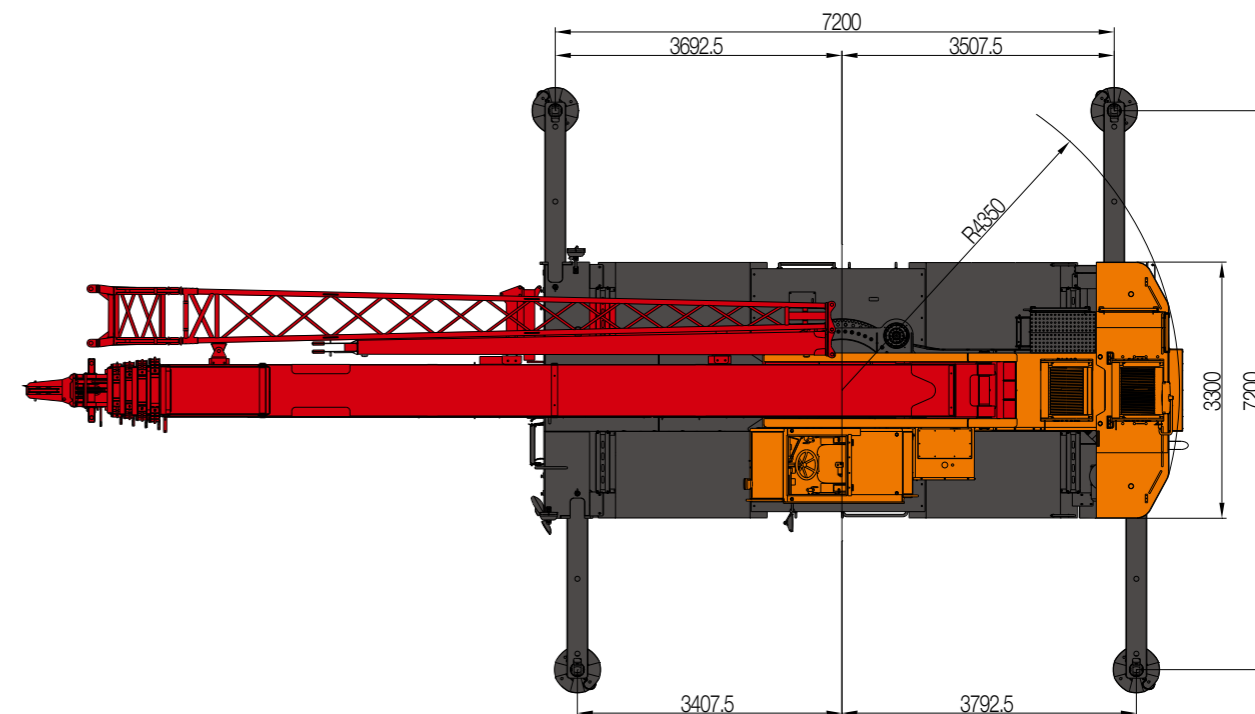
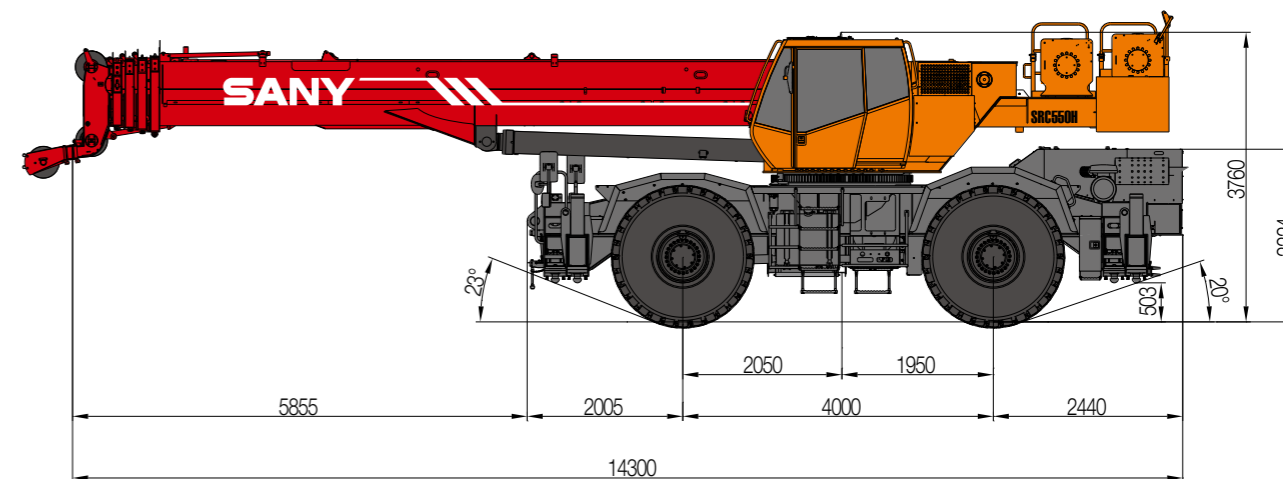

SRC550H Working Ranges

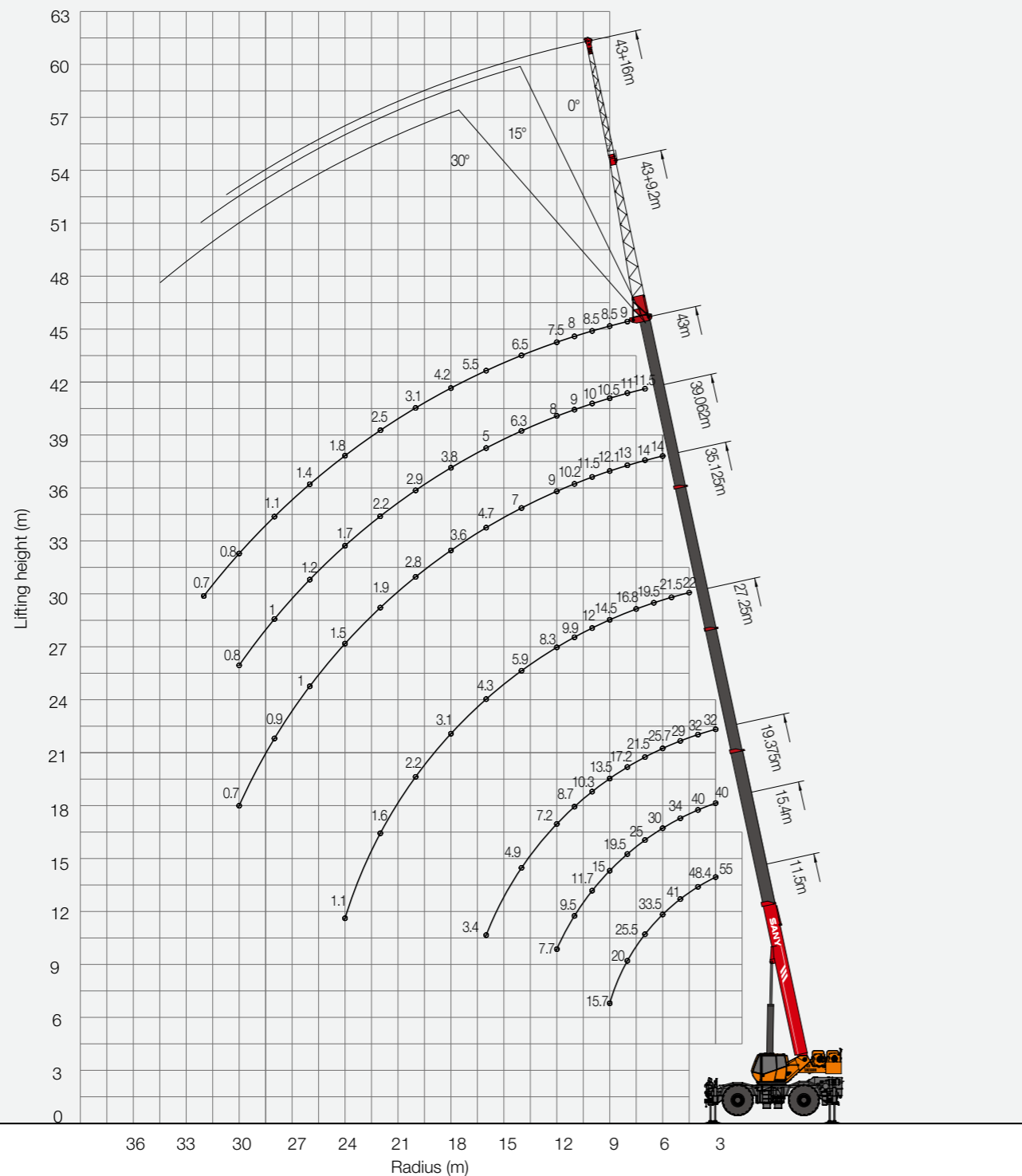

Prerequisites:

- ① Boom operating conditions (fully extended boom length), min. length is 11.5m and max. length is 43m
- ② The span of outriggers is 7.2m×7.2m
- ③ 360° rotation is applied
- ④ Counterweight is 4.5T

Working range(m)	Main boom							Working range(m)
	11.5m	15.437m	19.375m	27.250m	35.125m	39.062m	43.000m	
3.0	55000	40000	32000					3.0
3.5	53400	40000	32000					3.5
4.0	48400	40000	32000					4.0
4.5	44000	37000	31000	22000				4.5
5.0	41000	34000	29000	22000				5.0
5.5	36900	31000	27500	21500				5.5
6.0	33500	30000	25700	21000	14000			6.0
6.5	28500	28000	23900	19500	14000			6.5
7.0	25500	25000	21500	18000	14000	11500		7.0
7.5	23000	21500	18900	16800	13500	11500		7.5
8	20000	19500	17200	15800	13000	11000	9000	8
9	15700	15000	13500	14500	12100	10500	8500	9
10		11700	10300	12000	11500	10000	8500	10
11		9500	8700	9900	10200	9000	8000	11
12		7700	7200	8300	9000	8000	7500	12
14			4900	5900	7000	6300	6500	14
16			3400	4300	4700	5000	5500	16
18				3100	3600	3800	4200	18
20				2200	2800	2900	3100	20
22				1600	1900	2200	2500	22
24				1100	1500	1700	1800	24
26					1000	1200	1400	26
28					900	1000	1100	28
30					700	700	800	30
32							700	32
Min.elevation angle(°)	0°	0°	0°	0°	20°	35°	38°	Min.elevation angle(°)
Number of parts of line	10	10	8	6	4	4	3	Number of parts of line

Prerequisites:

- ① Boom operating conditions(boom length),min. length is 11.500m and max.length is 27.250m
- ② With tyre static lifting load
- ③ 360°rotation is applied
- ④ Counterweight is 4.5T

Working range(m)	Main boom				Working range(m)
	11.500m	15.437m	19.375m	27.250m	
3	12000	10500	10000		3
3.5	12000	10500	10000		3.5
4	10000	10000	9000		4
4.5	8600	8000	8000	5000	4.5
5	7000	6500	6000	5000	5
5.5	5800	4800	4500	5000	5.5
6	4300	3000	3000	4900	6
6.5	3000	2500	1850	3000	6.5
7	2250	1800	1350	2250	7
7.5	1700	1300	1000	1700	7.5
8	1200	900	500	1200	8
9				800	9
Min.elevation angle(°)	0°	49°	58°	65°	Min.elevation angle(°)
Number of parts of line	6	6	6	6	Number of parts of line

Prerequisites:

- ① Boom operating conditions(fully extended boom length),min. length is 11.5m and max.length is 43m
- ② The span of outriggers is 7.2m×5m
- ③ 360°rotation is applied
- ④ Counterweight is 4.5T

Working range(m)	Main boom							Working range(m)
	11.5m	15.437m	19.375m	27.250m	35.125m	39.062m	43.000m	
3.0	49650	37000	29100					3.0
3.5	45200	37000	29100					3.5
4.0	40000	37000	29100					4.0
4.5	33800	33000	28200	19100				4.5
5.0	29000	29550	26500	19100				5.0
5.5	24350	23650	23250	19100				5.5
6.0	20100	19450	19100	19100	14000			6.0
6.5	16900	16300	15950	17950	14000			6.5
7.0	14450	13850	13500	15400	14000	11500		7.0
7.5	12450	11850	11550	13350	13000	11500		7.5
8.0	10800	10250	9950	11700	11600	11000	9000	8.0
9.0	8300	7800	7500	9100	10000	9500	8500	9.0
10.0		6000	5700	7200	8100	8200	8200	10.0
11.0		4600	4300	5800	6600	6900	7000	11.0
12.0		3500	3200	4600	5450	5700	5900	12.0
14.0			1600	2950	3700	4000	4200	14.0
16.0				1800	2500	2750	2950	16.0
18.0				900	1600	1850	2050	18.0
20.0					900	1150	1350	20.0
22.0							800	22.0
Min.elevation angle(°)	0°	0°	0°	32°	46°	52°	55°	Min.elevation angle(°)
Number of parts of line	10	10	8	6	4	4	3	Number of parts of line

Prerequisites:

- ① Boom operating conditions(fully extended boom length),min. length is 11.5m and max.length is 43m
- ② The span of outriggers is 7.2m×3.1m
- ③ 360°rotation is applied
- ④ Counterweight is 4.5T

Working range(m)	Main boom							Working range(m)
	11.5m	15.437m	19.375m	27.250m	35.125m	39.062m	43.000m	
3.0	35150	34250						3.0
3.5	24750	23950	23500					3.5
4.0	18600	17900	17500					4.0
4.5	14500	13900	13500	15550				4.5
5.0	11600	11000	10650	12600				5.0
5.5	9450	8900	8550	10350				5.5
6.0	7700	7250	6900	8650	9600			6.0
6.5	6450	5900	5600	7250	8150			6.5
7.0	5350	4850	4550	6100	7000	7300		7.0
7.5	4450	3950	3650	5200	6050	6350		7.5
8.0	3700	3200	2900	4400	5250	5500	5750	8.0
9.0	2450	2000	1700	3150	3950	4200	4450	9.0
10.0		1050	1050	2150	2950	3200	3400	10.0
11.0				1400	2150	2400	2500	11.0
12.0				800	1500	1750	1950	12.0
14.0						800	1000	14.0
Min.elevation angle(°)	0°	0°	46°	58°	63°	65°	67°	Min.elevation angle(°)
Number of parts of line	8	8	8	4	3	3	3	Number of parts of line

Prerequisites:

- ① Boom operating conditions(boom length),min. length is 11.5m and max.length is 27.250m
- ② With tyre static lifting load,right ahead
- ③ Counterweight is 4.5T

Working range(m)	Main boom				Working range(m)
	11.500m	15.437m	19.375m	27.250m	
3.0	21300	21000	17700		3.0
3.5	19000	18800	15800		3.5
4.0	17000	16700	14100		4.0
4.5	15000	14800	12400		4.5
5.0	13700	13400	11700	12100	5.0
5.5	12400	12100	11100	11000	5.5
6.0	11100	10800	10500	9900	6.0
6.5	10100	9900	9700	9100	6.5
7.0	9300	8800	8700	8300	7.0
8.0	7700	7300	7300	7300	8.0
9.0	6400	6000	5900	6600	9.0
10.0		4800	4700	5700	10.0
11.0			3700	4700	11.0
12.0			2900	3800	12.0
14.0			1700	2600	14.0
16.0				1800	16.0
18.0				1150	18.0
20.0				600	20.0
Min.elevation angle(°)	0°	0°	0°	38°	Min.elevation angle(°)
Number of parts of line	6	6	6	6	Number of parts of line

Prerequisites:

- ① Boom operating conditions(boom length),min. length is 11.5m and max.length is 27.250m
- ② With lifting load traveling (right ahead)
- ③ Counterweight is 4.5T

Working range(m)	Main boom				Working range(m)
	11.500m	15.437m	19.375m	27.250m	
3.0	18100	14100	10200		3.0
3.5	16000	14100	9000		3.5
4.0	14300	14100	8000		4.0
4.5	12850	12650	7200	5500	4.5
5.0	11600	11400	6500	5000	5.0
5.5	10500	10300	6000	4500	5.5
6.0	9550	9350	5300	4200	6.0
6.5	8700	8400	4800	3800	6.5
7.0	7900	7500	4200	3500	7.0
7.5	7300	6600	3800	3200	7.5
8.0	6700	5800	3200	2900	8.0
9.0	5650	5000	2700	2500	9.0
10.0		4000	2200	2200	10.0
11.0			1700	1900	11.0
12.0				1500	12.0
14.0				1000	14.0
Min.elevation angle(°)	0°	32°	43°	53°	Min.elevation angle(°)
Number of parts of line	6	6	6	6	Number of parts of line

Prerequisites:

- ① Boom operating conditions(fully extended boom length+jib length),max.length is 43m+9.2m
- ② The span of outriggers is 7.2m×7.2m
- ③ 360°rotation is applied
- ④ Counterweight is 4.5T

Working range (feet)	Working range (m)	Main boom+Jib		
		0°	15°	30°
35	10.7	4250		
40	12.2	4050		
45	13.7	3850	3300	
50	15.2	3550	3100	2750
55	16.8	3200	2900	2600
60	18.3	2800	2600	2400
65	19.8	2350	2250	2100
70	21.3	1950	1900	1800
75	22.9	1600	1550	1500
80	24.4	1350	1300	1250
85	25.9	1100	1050	1000
90	27.4	900	850	850
95	29.0	700	750	750
100	30.5		650	700
105	32.0			600
110	33.5			
115	35.1			
Min.elevation angle of main boom with nonload(°)		47°	47°	49°

Prerequisites:

- ① Boom operating conditions(fully extended boom length+jib length),max.length is 43m+16m
- ② The span of outriggers is 7.2m×7.2m
- ③ 360°rotation is applied
- ④ Counterweight is 4.5T

Working range (feet)	Working range (m)	Main boom+Jib		
		0°	15°	30°
35	10.7			
40	12.2			
45	13.7	2700		
50	15.2	2550		
55	16.8	2400	1950	
60	18.3	2250	1900	
65	19.8	2000	1800	1350
70	21.3	1700	1650	1350
75	22.9	1450	1400	1300
80	24.4	1250	1200	1150
85	25.9	1100	1050	1000
90	27.4	1000	950	900
95	29.0	900	850	800
100	30.5	800	750	750
105	32.0	650	700	700
110	33.5		600	650
115	35.1			550
Min.elevation angle of main boom with nonload(°)		51°	51°	53°

1. Values listed in the table refer to rated lifting capacity measured at flat and solid ground under the lever state of the crane.
2. Value above heavy line shall be determined by strength of the crane and under this line shall be determined by stability of the crane.
3. Rated load values determined by stability shall comply with ISO 4305.
4. Rated lifting capacity listed in the table included weights of lifting hooks (660kg of main hook and 160kg of auxiliary hook)and hangers.
5. Rated lifting capacity with pulley at boom tip shall not exceed 6900kg.
6. If actual boom length and range are between two values specified in the table, larger value will determine the lifting capacity.

SRC550H ROUGH-TERRAIN CRANE
WHEEL CRANE FAMILY MAP

TRUCK CRANE



STC200
Maximum Load Capacity: 20t
Telescopic Boom: 4 Sections, 10.6-33m



STC250
Maximum Load Capacity: 25t
Telescopic Boom: 4 Sections, 10.65-33.5m



STC250H
Maximum Load Capacity: 25t
Telescopic Boom: 5 Sections, 10.5-39.5m



STC300TH
Maximum Load Capacity: 30t
Telescopic Boom: 4 Sections, 10.6-33.5m



STC300H
Maximum Load Capacity: 30t
Telescopic Boom: 5 Sections, 10.5-39.5m



STC500
Maximum Load Capacity: 50t
Telescopic Boom: 5 Sections, 11.5-43m



STC550
Maximum Load Capacity: 55t
Telescopic Boom: 5 Sections, 11.5-43m



STC550EYR
Maximum Load Capacity: 55t
Telescopic Boom: 5 Sections, 11.5-43m



STC600
Maximum Load Capacity: 60t
Telescopic Boom: 5 Sections, 11.5-43m



STC750
Maximum Load Capacity: 75t
Telescopic Boom: 5 Sections, 11.8-45m



STC800
Maximum Load Capacity: 80t
Telescopic Boom: 5 Sections, 11.8-45m



STC800EYR
Maximum Load Capacity: 80t
Telescopic Boom: 5 Sections, 11.8-45m



STC1000
Maximum Load Capacity: 100t
Telescopic Boom: 5 Sections, 13.5-52m



STC1000C
Maximum Load Capacity: 100t
Telescopic Boom: 6 Sections, 13.25-60m



STC1300C
Maximum Load Capacity: 130t
Telescopic Boom: 6 Sections, 13.3-60m

ALL TERRAIN CRANE



SAC1800
Maximum Load Capacity: 180t
Telescopic Boom: 6 Sections, 13.5-62m



SAC2200
Maximum Load Capacity: 220t
Telescopic Boom: 6 Sections, 13.5-62m



SAC3000
Maximum Load Capacity: 300t
Telescopic Boom: 7 Sections, 15.4-80m



SAC3500
Maximum Load Capacity: 350t
Telescopic Boom: 6 Sections, 15.2-70m



SAC6000
Maximum Load Capacity: 600t
Telescopic Boom: 7 Sections, 17.1-90m

ROUGH-TERRAIN CRANE



SRC350
Maximum Load Capacity: 35t
Telescopic Boom: 4 Sections, 10-31.5m



SRC550
Maximum Load Capacity: 55t
Telescopic Boom: 4 Sections, 11.25-34.5m



SRC550H
Maximum Load Capacity: 55t
Telescopic Boom: 5 Sections, 11.5-42.5m



SRC750
Maximum Load Capacity: 75t
Telescopic Boom: 5 Sections, 11.8-45m



Quality Changes the World

SANY AUTOMOBILE HOISTING MACHINERY

Address: SANY Industrial Park, Jinzhou Development Zone,
Changsha, Hunan, China.
Service Hotline: 4006098318
Email: crd@sany.com.cn
For more information, please visit: www.sanygroup.com

For our consistent improvement in technology, specifications may change without notice.
The machines illustrated may show optional equipment which can be supplied at additional cost.

Distributed By: