

SRC400

SRC400 ROUGH-TERRAIN CRANE 40 TONS LIFTING CAPACITY

Quality Changes the World

MAX. CAPACITY (Outriggers) - 40 Tonnes at 3.05m Radius (75% Rating) 360° Slew
--

BOOM - 4 SECTION U-Shaped 10m - 31.5m
--

MAX. ROAD SPEED - 37km/hr

CARRIER - 4x4 Drive

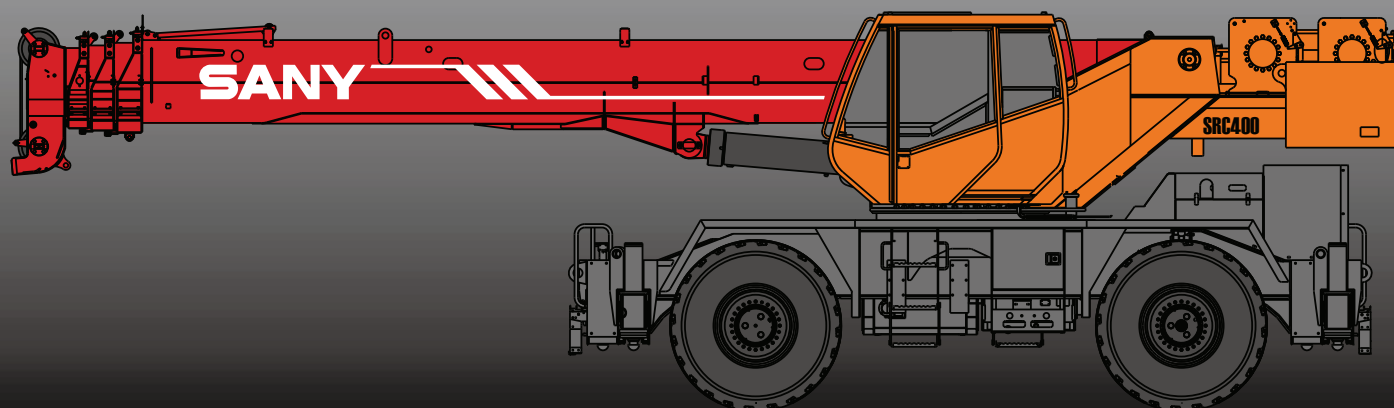

SANY

- SANY Automobile Hoisting Machinery is one of the core business unit of Sany Heavy Industry, mainly engaged in the research and development of high end, mid to large tonnage crane series, including mobile crane, crawler crane, tower crane and loader crane. It has two industrial parks in Ningxiang and Huzhou, since entering the market, the products of Sany Automobile Hoisting Machinery have received worldwide recognition with advanced technology, lean manufacturing, high reliability and excellent service.





SANY ROUGH-TERRAIN CRANE

CONTENT

- 04 Icon
- 05 Selling points
- 06 Introduction
- 09 Dimension
- 11 Technical Parameter
- 12 Operation Condition
- 13 Load Chart
- 17 Wheel Crane Family Map

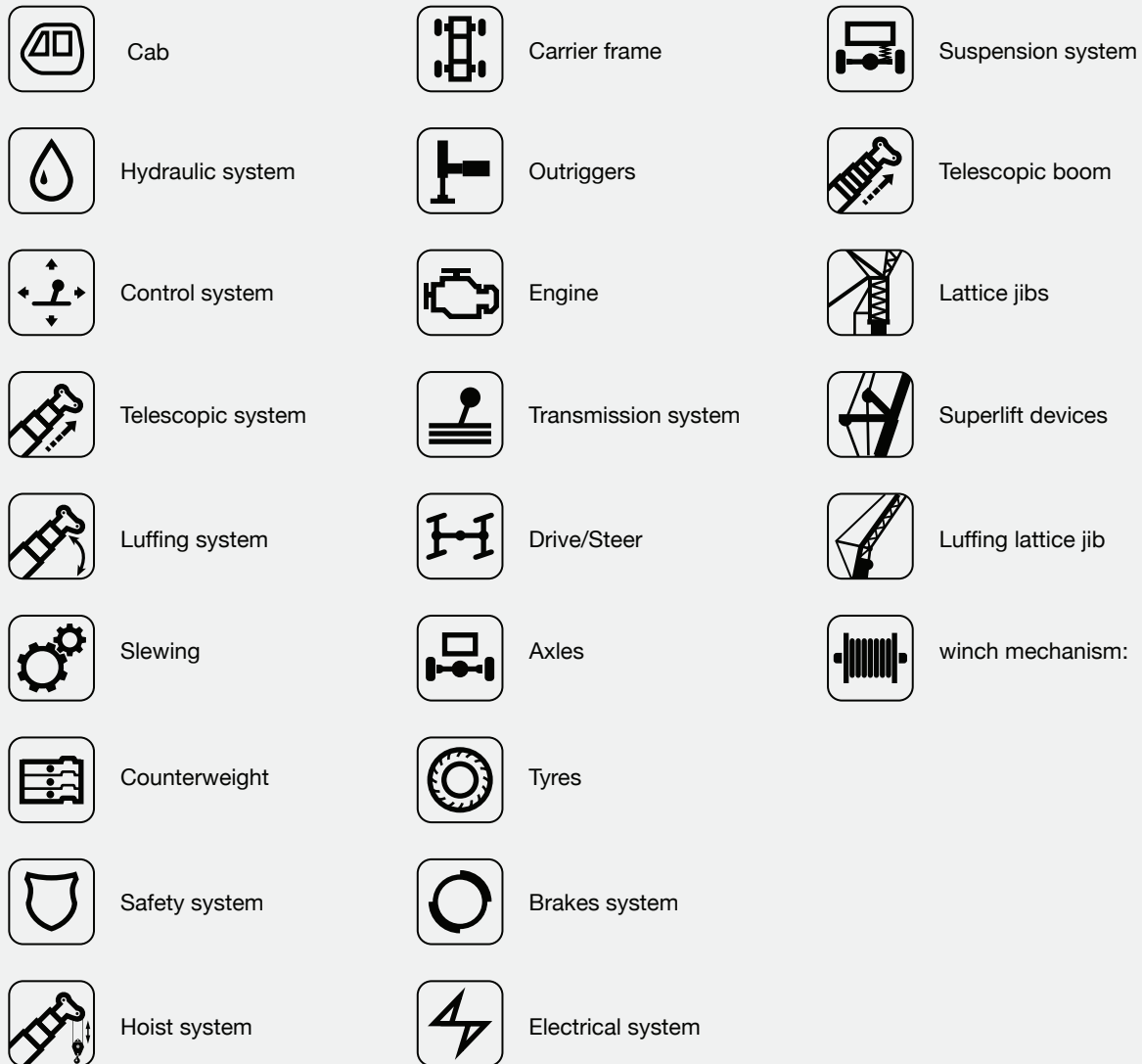



Excellent traveling capacity and high-performance chassis system

Four-wheel drive is applied with four steering modes to provide good mobility. Trafficability and comfortableness of the complex road condition is improved thanks to its Min. turning radius of no more than 6.2m with 4-wheel steering.

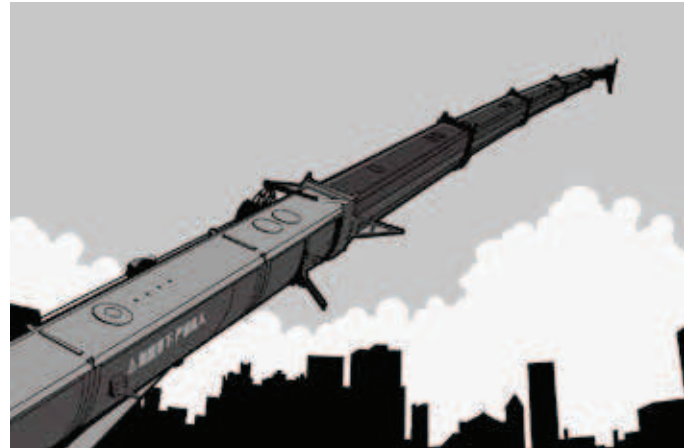

Ultra long and super strong boom system

Four-section boom of high strength steel structure and optimized U-shaped section, reducing weight and improving safety significantly. Jib mounting angles are 0°, 15°, and 30°, which ensure fast and convenient change-over between different operating conditions so as to improve working efficiency of the machine.



Highly efficient and unique hydraulic system

Hydraulic system load feedback and constant power control is applied to provide strong lifting capacity and good micro-mobility. Unique steering buffer design guarantees smooth braking operation.



Safe and reliable control system

Self-developed controller SYMC specially for engineering machinery is configured. The application of CAN-bus fully digital network control technology ensures stable control signal, simple harness and high reliability. It can feedback the data information and monitor the working condition of whole crane in real-time. Load moment limiter configured with comprehensive intelligent protection system is adopted with precision within 10%. The adoption of comprehensive logic and interlock control system ensures more safe and reliable operation.

Introduction

 Cab

- The self-made cab adopts ergonomic design with sliding door, safety glass, anti-corrosion steel, soft interior decoration, large interior space, panoramic sunroof and adjustable seats, air conditioner and electric window wiper etc. to provide easier and more comfortable operation. Load moment limiter display is configured to achieve the combination of main console and operating display system, making all operating condition data of lifting operation clear at a glance.

 Hydraulic system

- High-quality key hydraulic components such as main oil pump, rotary pump, main valve, winch motor and balancing parts etc. are adopted to achieve stable and reliable operation of the hydraulic system. Superior operation performance is guaranteed by accurate parameter matching. Through the adoption of load sensitive variable displacement piston pump, pump displacement can be adjusted in real-time, achieving high-precision flow control with no energy loss during operation.
- Main valve has flow compensation and load feedback control function. It significantly enhances control stability for single action and combined action under different operation conditions.
- Winch adopts electronically controlled variable motor to ensure high operation efficiency. Max. single line speed of main and auxiliary winches is up to 140m/min;
- Slewing system is equipped with the integrated slewing buffer valve with free slipping function to ensure more stable starting and control of the slewing operation and excellent micro-mobility.
- Hydraulic oil tank capacity: 530L.

 Control system

- CAN-bus instrument: CAN-bus instrument with a combined intelligent control electrical system is used for easy reading of the traveling parameters at any time. Engine fault warning function enables convenient and fast maintenance.
- With full security protection system, main and auxiliary winches are equipped with over-rollback limiter and height limiters to prevent over-rolling out and over-hoisting of steel rope, including tip-over and limit angle protection.
- Load moment limiter: The adoption of highly intelligent load moment limiter system can comprehensively protect lifting operation, ensuring accurate, stable and comfort operation.

 Telescopic system

- Four-section boom is applied with basic boom length of 10m, full-extended boom length of 31.5m, jib length of 13.7m and fully extended boom tip height of 33.9m respectively, Max. tip height is 47.4m including jib. It is made of fine grain high-strength steel with U-shaped cross section and with telescopic operation controlled independently by single cylinder rope.

 Luffing system

- Dead-weight luffing provides more stable luffing operation at low energy loss. Dual-action single piston hydraulic pressure cylinder with safety valve is adopted. Luffing angle range is -2° — 78° .

Introduction



Slewing system

- 360° rotation can be achieved with Max. slewing speed of 2.7r/min. Hydraulic controlled proportional speed adjustment is applied, providing stable and reliable operation of the system. Unique slewing buffer design ensures more stable braking operation.



Counterweight

- The total weight of fixed counterweight is 4000kg, no flexible counterweight.



Safety system

- Load moment limiter: Load moment limiter calculation system based on lifting load mechanical model is established using an analytical mechanics method with rated lifting accuracy up to 0-10% through on-line non-load calibration, providing full protection to lifting operation. In case of overload operation, system will automatically issue an alarm to provide safety protection for manipulation.
- Hydraulic system is configured with the balance valve, overflow valve and two-way hydraulic lock etc. components, thus achieving stable and reliable operation of the hydraulic system.
- Main and auxiliary winches are equipped with over roll-out limiter to prevent over rolling-out of wire rope.
- Boom and jib ends are equipped with height limiters respectively to prevent over-hoisting of wire rope.
- Equipped with length sensor, angle sensor and press sensor to indicate the working condition of whole crane in real-time, giving an alarm and cutting off the dangerous action automatically.



Hoist system

- The adoption of pump and motor double variable speed control ensures high efficiency and excellent energy saving functionality. With perfect combination of winch balance valve and unique anti-slip technology, heavy load can be lifted and lowered smoothly. High strength, anti-swirl steel wire is equipped for high-precision hoisting positioning.
- Equipped with one 360kg main hook and one 160kg auxiliary hook, and main and auxiliary hook steel rope diameters are 16mm, the rope length is 165m and 135m respectively.



Carrier frame

- Carrier frame is of box-type structure that is welded with high-strength steel plate, featuring high lifting capacity.

Introduction

**Outriggers**

- H-type outrigger structure and 4-point support is adopted with Max. span up to 6.15m×6.15m, featuring easy operation and high stability. Fine grain high strength steel material is adopted and dual-direction hydraulic lock is used for the protection of vertical cylinder of outrigger.

**Engine**

- Type: Inline six-cylinder, water cooled, supercharged and inter-cooling diesel engine
- Rated power: 119kw/2500r/min
- Environment-protection: Emission complies with Tier III standard
- Capacity of fuel tank: 300L

**Transmission system**

- Transmission case: Automatic transmission case. There are six forward gears and six backward gears in gearbox. The speed ratio range is large which meets the requirements of low gradeability speed and high traveling speed.
- Transmission shaft: With optimized arrangement of the transmission shaft, the transmission is stable and reliable.

**Drive/Steer**

- 4×4 drive ways and full hydraulic power steering system with front wheel steering, rear wheel steering, four-wheel steering, and crab traveling modes.

**Axles**

- Axles can be flexibly controlled with two-axle designed for chassis. Front and rear axles drive are applied to ensure good power performance.

**Tyres**

- Tyres type 4* 20.5R25 ★★ 177B193A2 TL ET5A

**Brakes system**

- Double-circuit braking system is adopted, if one circuit fails, the other circuit can ensure normal operation, thus improving the safety and reliability of brake system.

**Electrical system**

- With 24V free maintenance battery and mechanical power main switch, power of the whole machine can be cut off manually.

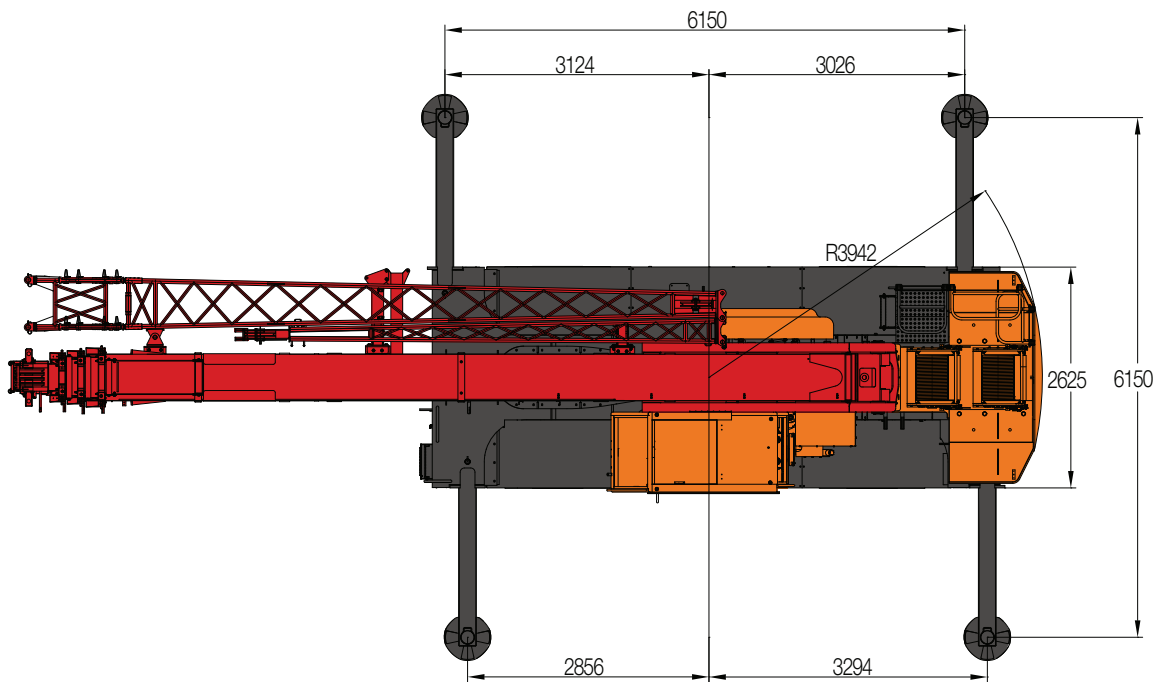
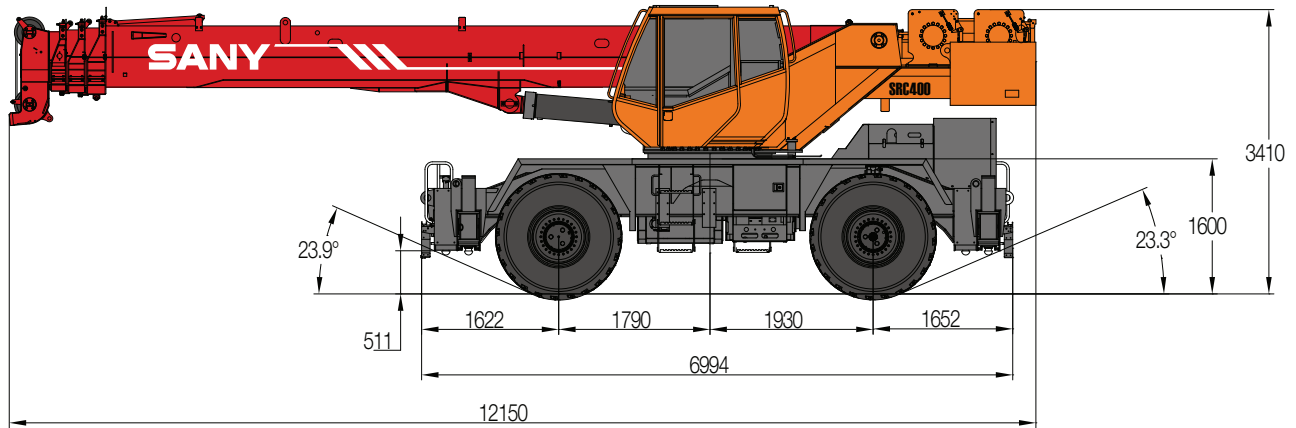

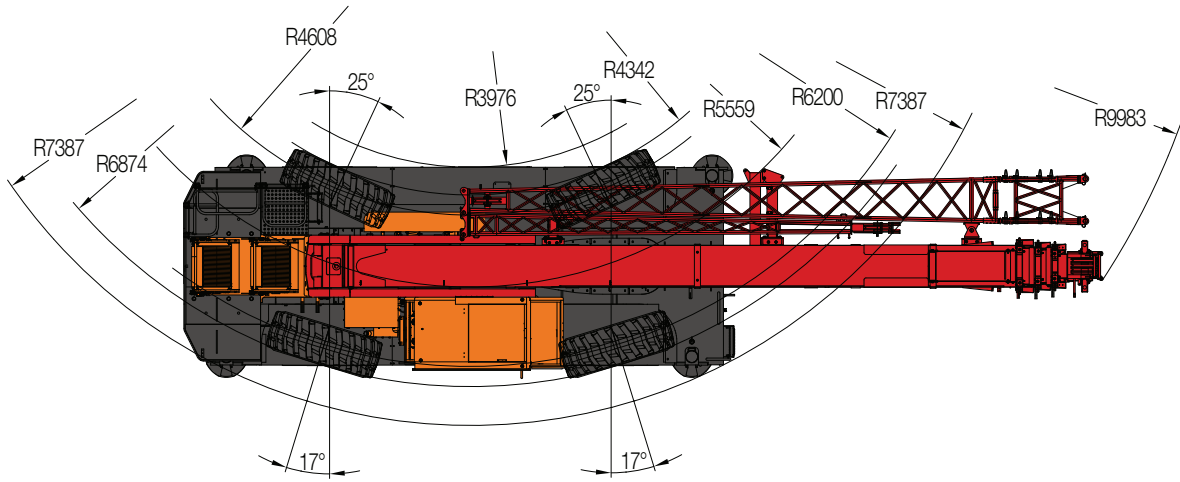
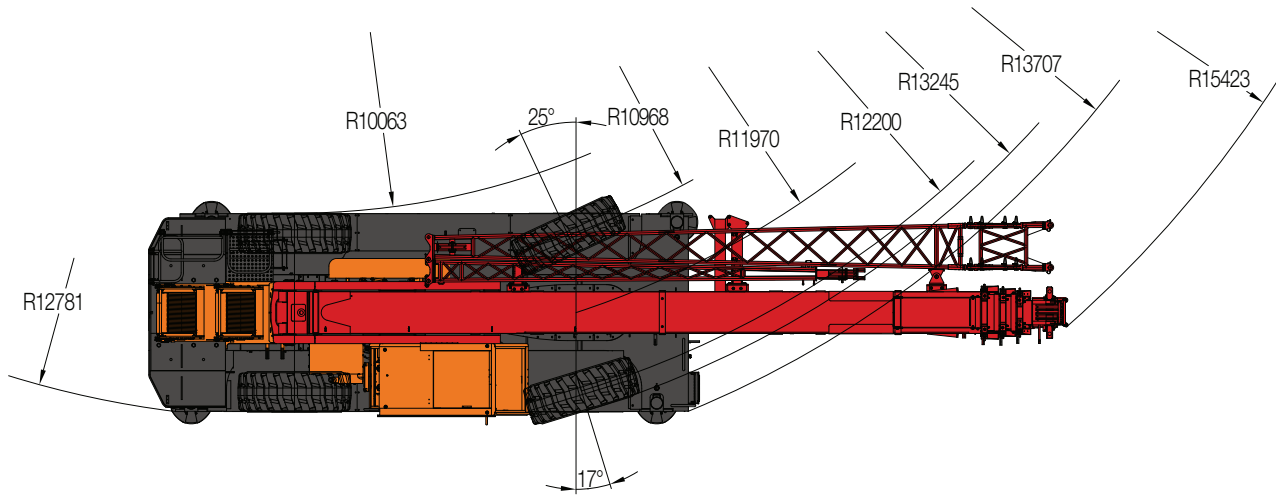

Type	Item	Parameter	
Capacity	Max. lifting capacity	40 t	
Dimensions	Overall length	12150mm	
	Overall width	2625 mm	
	Overall height	3410 mm	
	Axle distance	3720 mm	
Weight	Overall weight	32300 kg	
	Axle load	Front axle load	16640 kg
		Rear axle load	15660 kg
	Rated power	119 kW/ 2500 rpm	
Rated torque	732 N.m/ 1500 rpm		
Traveling	Max.traveling speed	37 km/h	
	Turning radius	Min.turning radius	12.2/6.2 m
	Wheel formula	4× 4	
	Min.ground clearance	400 mm	
	approach angle	23.9 °	
	Departure angle	23.3 °	
	Max.gradeability	75%	
	Fuel consumption per 100km	≤55 L	
Main Performance Data	Temperature range	- 20 °C ~ + 46°C	
	Min.rated range	3.05 m	
	Tail slewing radius of swingtable	3.94 m	
	Boom section	4	
	Boom shape	U-shaped	
	Max.lifting moment	Base boom	1139 kN·m
		Full-extend boom	743 kN·m
		Full-extend boom+jib	330 kN·m
	Boom length	Base boom	10 m
		Full-extend boom	31.5 m
		Full-extend boom+jib	45.2 m
Outrigger span (Longitudinal×Transversal)	6.15 × 6.15 m		
Jib offset	0 °, 15 °, 30 °		
Working speed	Max.single rope lifting speed of main winch (no load)	140 m/min	
	Max.single rope lifting speed of auxiliary winch (no load)	140 m/min	
	Full extension/retraction time of boom	55 / 39 s	
	Full lifting/descending time of boom	43 / 57 s	
	Slewing speed	2.7 r/min	
Aircondition	Aircondition in cab	Cooling/Heating & Cooling	

SRC400 Working Ranges

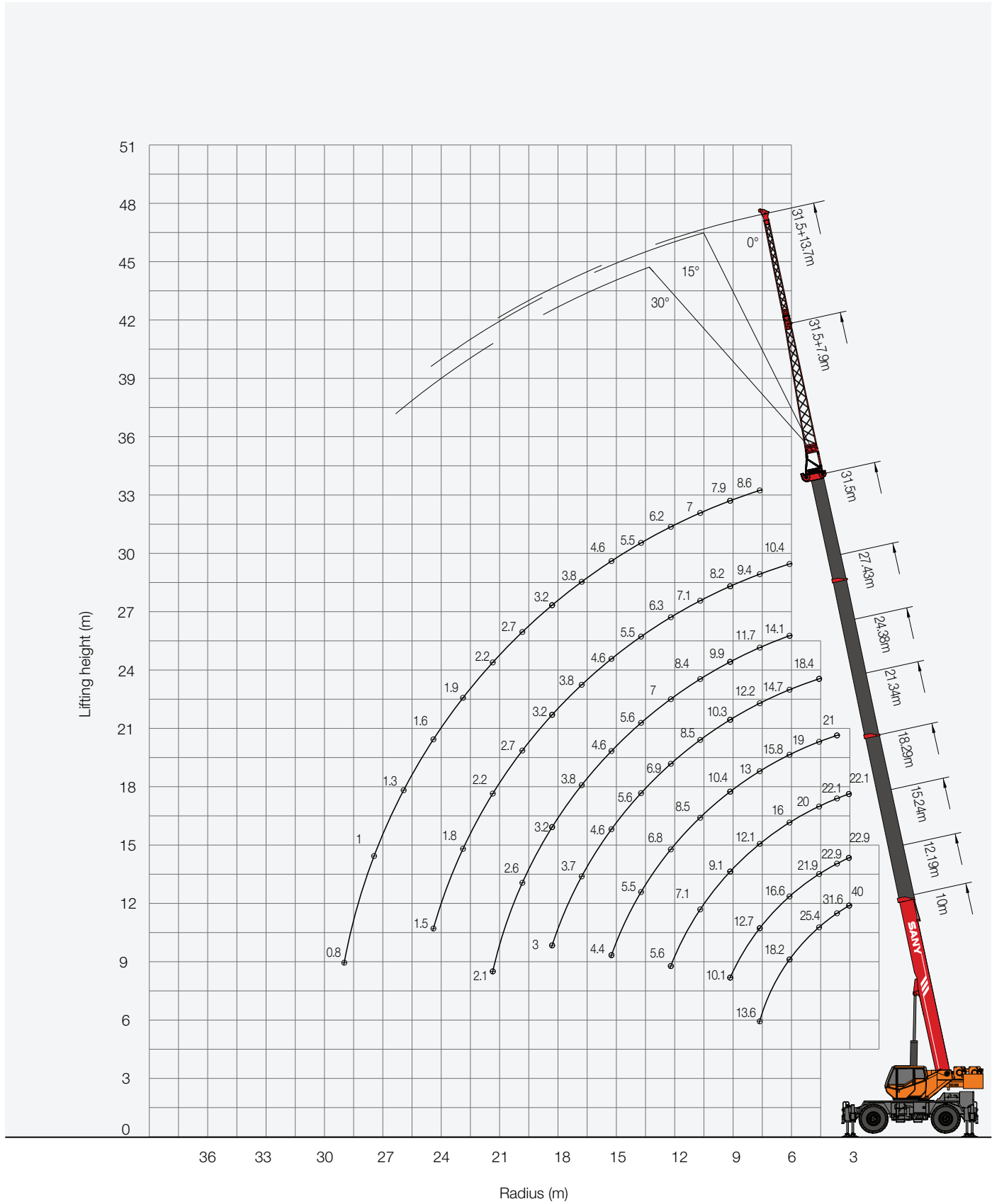

Metric 75% Lifting Capacities (Kilograms) on Outriggers Fully Extended.

Prerequisites:

- ① Boom operating conditions (fully extended boom length), min. length is 10m and max. length is 31.5m
- ② The span of outriggers is 6.15m x 6.15m
- ③ 360° rotation is applied
- ④ Counterweight is 4T

Working range (m)	Main boom								Working range (m)
	10m	12.19m	15.24m	18.29m	21.34m	24.38m	27.43m	31.5m	
3.05	40000	22997	22100						3.05
3.66	31610	22997	22100	21050					3.66
4.58	25400	21954	20000	19000	18432				4.58
6.10	18200	16670	16000	15800	14764	14145	10400		6.10
7.63	13630	12764	12156	13050	12288	11716	9400	8600	7.63
9.15		10121	9131	10407	10383	9906	8250	7900	9.15
10.68			7109	8525	8597	8478	7100	7050	10.68
12.20			5661	6882	6977	7049	6300	6200	12.20
13.73				5549	5620	5668	5590	5520	13.73
15.25				4480	4610	4653	4660	4660	15.25
16.78					3777	3848	3860	3870	16.78
18.30					3097	3201	3220	3240	18.30
19.83						2644	2700	2720	19.83
21.35						2180	2260	2280	21.35
22.88							1860	1920	22.88
24.40							1530	1600	24.40
25.93								1300	25.93
27.45								1050	27.45
28.98								820	28.98
Min.elevation angle(°)	/	/	/	/	/	/	/	/	Min.elevation angle(°)
Number of parts of line	8	6	6	4	4	4	4	3	Number of parts of line

Prerequisites:

- ① Boom operating conditions (fully extended boom length), min. length is 10m and max. length is 31.5m
- ② The span of outriggers is 6.15m x 4.27m
- ③ 360° rotation is applied
- ④ Counterweight is 4T

Working range (m)	Main boom								Working range (m)
	10m	12.19m	15.24m	18.29m	21.34m	24.38m	27.43m	31.5m	
3.05	40000	22997	22100						3.05
3.66	30050	22997	22100	21050					3.66
4.58	22000	19000	18200	17500	18432				4.58
6.10	13600	13650	13700	13900	14100	14145	10400		6.10
7.63	8799	9215	9597	9853	10038	10179	8900	8600	7.63
9.15		6460	6807	7040	7207	7335	7300	7100	9.15
10.68			5014	5232	5388	5506	5597	5693	10.68
12.20			3766	3972	4120	4232	4319	4408	12.20
13.73				3044	3186	3293	3376	3462	13.73
15.25				2332	2469	2573	2653	2736	15.25
16.78					1902	2003	2081	2161	16.78
18.30					1442	1541	1616	1694	18.30
19.83						1158	1232	1308	19.83
21.35						837	909	984	21.35
22.88							634	707	22.88
Min.elevation angle(°)	/	/	/	/	/	0°	22°	35°	Min.elevation angle(°)
Number of parts of line	8	6	6	4	4	4	4	3	Number of parts of line

**SRC400 ROUGH-TERRAIN CRANE
LOAD CHART**
Prerequisites:

- ① **Boom operating conditions(fully extended boom length),min. length is 10m and max.length is 31.5m**
- ② **The span of outriggers is 6.15m×2.39m**
- ③ **360°rotation is applied**
- ④ **Counterweight is 4T**

Working range (m)	Main boom								Working range (m)
	10m	12.19m	15.24m	18.29m	21.34m	24.38m	27.43m	31.5m	
3.05	23600	22700	22100						3.05
3.66	15484	16025	16520	16853					3.66
4.58	10286	10748	11170	11454	11659				4.58
6.10	5933	6329	6690	6932	7106	7239	7341		6.10
7.63	3648	4007	4336	4555	4713	4833	4925	5021	7.63
9.15		2576	2884	3090	3238	3350	3435	3524	9.15
10.68			1900	2097	2237	2344	2425	2509	10.68
12.20			1190	1379	1514	1617	1695	1776	12.20
13.73				836	967	1067	1143	1221	13.73
15.25					539	636	710	786	15.25
Min.elevation angle(°)	/	/	/	23°	36°	44°	49°	55°	Min.elevation angle(°)
Number of parts of line	6	6	6	4	4	4	4	3	Number of parts of line

Prerequisites:

- ① **Boom operating conditions(boom length),min. length is 10m and max.length is 18.29m**
- ② **With lifting load traveling (right ahead) \leq 4km/h**
- ③ **Counterweight is 4T**

Working range (m)	Main boom				Working range (m)
	10m	12.19m	15.24m	18.29m	
3.05	12315	12202			3.05
3.66	10591	10546			3.66
4.58	8596	8664	8800		4.58
6.10	6214	6441	6577	6600	6.10
7.63	4581	4876	5058	5080	7.63
9.15		3607	3910	3987	9.15
10.68			2689	2883	10.68
12.20			1824	2011	12.20
13.73				1362	13.73
15.25				860	15.25
Min.elevation angle(°)	/	/	/	/	Min.elevation angle(°)
Number of parts of line	4	4	4	4	Number of parts of line

Prerequisites:

- ① Boom operating conditions(boom length),min.length is 10m and max.length is 18.29m
- ② With tyre static lifting load
- ③ 360° rotation is applied
- ④ Counterweight is 4T

Working range (m)	Main boom				Working range (m)
	10m	12.19m	15.24m	18.29m	
3.05	10909	10932	10433		3.05
3.66	8907	9092	8907		3.66
4.58	6917	7053	7303	6305	4.58
6.10	3962	4255	4472	4472	6.10
7.63	2188	2525	2833	2953	7.63
9.15		1402	1693	1888	9.15
10.68			914	1101	10.68
12.20				530	12.20
Min.elevation angle(°)	/	/	/	/	Min.elevation angle(°)
Number of parts of line	4	4	4	4	Number of parts of line

Prerequisites:

- ① Boom operating conditions(fully extended boom length+jib length),max.length is 31.5m+13.7m
- ② The span of outriggers is 6.15m×6.15m
- ③ 360°rotation is applied
- ④ Counterweight is 4T

Working angle (°)	Main boom+jib			Working angle (°)
	0°	15°	30°	
78°	2250	1250	900	78°
77°	2150	1200	900	77°
75°	1950	1150	850	75°
73°	1750	1100	800	73°
71°	1600	1050	750	71°
68°	1450	1000	700	68°
66°	1350	950	660	66°
63°	1150	850	600	63°
61°	1050	750	550	61°
58°	650	600	500	58°
56°	500			56°
Min.elevation angle(°)	34°	37°	39°	Min.elevation angle(°)

Prerequisites:

- ① **Boom operating conditions(fully extended boom length+jib length),max.length is 31.5m+7.9m**
- ② **The span of outriggers is 6.15m×6.15m**
- ③ **360°rotation is applied**
- ④ **Counterweight is 4T**

Working angle (°)	Main boom+jib			Working angle (°)
	0°	15°	30°	
78°	4000	2150	1650	78°
77°	3300	2100	1600	77°
75°	3100	2000	1550	75°
73°	2800	1900	1500	73°
71°	2600	1800	1400	71°
68°	2300	1650	1250	68°
66°	2100	1550	1150	66°
63°	1800	1350	1000	63°
61°	1500	1200	850	61°
58°	1100	950	650	58°
56°	700	650	500	56°
Min.elevation angle(°)	32°	34°	35°	Min.elevation angle(°)

1. Values listed in the table refer to rated lifting capacity measured at flat and solid ground under the lever state of the crane.
2. Value above heavy line shall be determined by strength of the crane and under this line shall be determined by stability of the crane.
3. All rated loads are tested to conform requirements of EN 13000 & ISO 4305 and shall not exceed 75% of the tipping load on outriggers and tyres under stability test code.
4. Rated lifting capacity listed in the table included weights of lifting hooks (360kg of main hook and 160kg of auxiliary hook)and hangers.
5. Rated lifting capacity with pulley at boom tip shall not exceed 5240kg.
6. If actual boom length and range are between two values specified in the table, larger value will determine the lifting capacity.

TRUCK CRANE



SPC250
Maximum Load Capacity: 25t
Telescopic Boom: 4 Sections, 10.22-31.5m



STC200
Maximum Load Capacity: 20t
Telescopic Boom: 4 Sections, 10.6-33m



STC250
Maximum Load Capacity: 25t
Telescopic Boom: 4 Sections, 10.65-33.5m



STC250H
Maximum Load Capacity: 25t
Telescopic Boom: 5 Sections, 10.5-39.5m



STC300TH
Maximum Load Capacity: 30t
Telescopic Boom: 4 Sections, 10.6-33.5m



STC300H
Maximum Load Capacity: 30t
Telescopic Boom: 5 Sections, 10.5-39.5m



STC500
Maximum Load Capacity: 50t
Telescopic Boom: 5 Sections, 11.5-43m



STC550
Maximum Load Capacity: 55t
Telescopic Boom: 5 Sections, 11.5-43m



STC600
Maximum Load Capacity: 60t
Telescopic Boom: 5 Sections, 11.5-43m



STC750
Maximum Load Capacity: 75t
Telescopic Boom: 5 Sections, 11.8-45m



STC800
Maximum Load Capacity: 80t
Telescopic Boom: 5 Sections, 11.8-45m



STC1000C
Maximum Load Capacity: 100t
Telescopic Boom: 6 Sections, 13.25-60m



STC1300C
Maximum Load Capacity: 130t
Telescopic Boom: 6 Sections, 13.3-60m

ALL TERRAIN CRANE



SAC1800
Maximum Load Capacity: 180t
Telescopic Boom: 6 Sections, 13.5-62m



SAC2200
Maximum Load Capacity: 220t
Telescopic Boom: 6 Sections, 13.5-62m



SAC3000
Maximum Load Capacity: 300t
Telescopic Boom: 7 Sections, 15.4-80m



SAC3500
Maximum Load Capacity: 350t
Telescopic Boom: 6 Sections, 15.2-70m



SAC6000
Maximum Load Capacity: 600t
Telescopic Boom: 7 Sections, 17.1-90m



SAC12000
Maximum Load Capacity: 120t
Telescopic Boom: 8 Sections, 18.6-102m

ROUGH-TERRAIN CRANE



SRC400
Maximum Load Capacity: 40t
Telescopic Boom: 4 Sections, 10-31.5m



SRC550
Maximum Load Capacity: 55t
Telescopic Boom: 4 Sections, 11.25-34.5m



SRC550H
Maximum Load Capacity: 55t
Telescopic Boom: 5 Sections, 11.5-42.5m



SRC750
Maximum Load Capacity: 75t
Telescopic Boom: 5 Sections, 11.8-45m



Quality Changes the World

SANY HEAVY INDUSTRY INDIA PVT. LTD.

HEAD OFFICE

Address : Plot No. E-4, Chakan Industrial Area Phase-III,
Village : Kuruli, Taluka: Khed, District: Pune - 410501, Maharashtra, INDIA.
Tel : +91 21 35670288, Fax: +91 21 35670300
E-mail : customercare@sany.in
Website : www.sany.in

Toll Free No.: 1800-209-3337



Materials and specifications are subject to change without notice. Featured machines in photos may include additional equipment
Copyright 2015 © SANY all rights reserved.

V: 2015/9